

# Air-Cooled ***DIESEL GENERATOR***

**OPERATION** **MANUAL**



An No.: DG2500(E) DG3500SE  
DG3000(E) DG4500SE  
DG4000(E) DG5500SE  
DG5000(E) DG6500SE  
DG6000(E) DG6500SE-N

**CE EPA**

## PREFACE

Thank you for purchasing products . We appreciate your business. The following manual is only a guide to assist you and is not a complete or comprehensive manual of all aspects of maintaining and repairing your generator. The equipment you have purchased is a complex piece of machinery. We recommend that you consult with a dealer if you have doubts or concerns as to your experience or ability to properly maintain or repair your equipment. You will save time and the inconvenience of having to go back to the store if you choose to write or call us concerning missing parts, service questions, operating advise, and/or assembly questions.

Our air-cooled diesel generators have some of the following features:

- Lightweight construction
- Air cooled
- Four-stroke diesel internal combustion engine
- Direct fuel injection system
- Recoil starter or an optional electric starter
- Large fuel tank
- Automatic voltage stabilizer
- NFB circuit protector
- AC and DC outputs
- Low oil pressure sensor

The air-cooled diesel generators are widely used when electrical power is scarce. Our generators provide a portable mobile solution in supplying power for field operations during project construction. Some other known applications include pipeline construction and metal welding when electrical power is not available.

This manual will explain how to operate and service your generator set.

If you have any questions or suggestions about this manual. please contact your local dealer or us directly. *Consumers should notice that this manual might differ slightly from the actual product as more improvements are made to our products. Some of the pictures in this manual may differ slightly from the actual product as well. Eastern Tools and Equipment, Inc. reserves the right to make changes at any time without notice and without incurring any obligation.*

## TABLE OF CONTENTS

Overall view of the generator	1
Chapter 1 Technical Specifications and Data	2
1-1 Technical specifications and data	4
1-2 Basic parameters	4
Chapter 2 Operating the Diesel Generator	5
2-1 General main points of safety during operation of the generator set	5
2-2 Preparation before operation	7
2-3 Checking the operation of the diesel engine	10
2-4 Starting the generator set	10
2-5 Procedures for starting the generator set	12
2-6 Proper operation of the generator set	14
2-7 Loading	14
2-8 Stopping the generator	15
Chapter 3 Maintenance	17
3-1 Maintenance schedules	17
3-2 Storing for long periods of times	19
Chapter 4 Troubleshooting	20
4-1 Troubleshooting procedures	20
4-2 Questions and doubts	20
Chapter 5 PARTLISTINGS	21

1. Overall view of DG4000E



2. Overall view of DG6000E



3. Overall view of DG6500SE(OLD)



4. Overall view of DG6500SE(NEW)



# CHAPTER 1. TECHNICAL SPECIFICATIONS AND DATA

## 1-1 Technical specifications and data(in Engine units)

Item \ Model		DG3500SE		DG4500SE		DG5500SE		DG6500SE		DG6500SE-N		DG7500SE		DG8500SE	
		50	60	50	60	50	60	50	60	50	60	50	60	50	60
Generator	Frequency(Hz)	50	60	50	60	50	60	50	60	50	60	50	60	50	60
	Max.output(kW)	3	3.3	3.3	3.5	4.6	5	5	5.5	4.6	5	6.0	6.5	6.5	7.0
	Rated output(kW)	2.8	3	3	3.3	4.2	4.6	4.6	5	4.2	4.6	5.5	6.0	6.0	6.5
	Rated AC voltage(V)	120,220,230,120/240,220/380													
	Power factor(COSΦ)	COSΦ=1													
	DC output(V)	12V/8.3A													
	Phase	Single phase or Three phase													
	Alternator type	self-excited,2-pole,single phase alternator													
	Starting system	Electric													
	Operating noise level(at 7m)	68-72								65-68		68-72			
	Fuel tank capacity(L)	16													
	Continues work(hr)	13	11.8	12.2	11.1	10.2	9.3	8.5	7.8	9.3	8.5	8	7.3	7.8	7.1
Engine	Model	HR178F		HR178FA		HR186F		HR186FA		HR186FA		HR188FA		HR192FB	
	Engine type	Single-cylinder,vertical,4-stroke air-cooled diesel engine													
	Bore × stroke(mm)	78 × 62		78 × 64		86 × 70		86 × 72		86 × 72		88 × 75		92 × 75	
	Fuel	0# or - 10# light diesel oil													
	Lubrication oil volume(L)	1.1				1.65									
	Combustion system	Direct injection													
Standard features	Voltmeter	yes		yes		yes		yes		yes		yes		yes	
	AC Output Socket	2		2		2		2		2		2		2	
	AC circuit breaker	yes		yes		yes		yes		yes		yes		yes	
	Oil warning light	yes		yes		yes		yes		yes		yes		yes	
	Oil alert	yes		yes		yes		yes		yes		yes		yes	
	DC circuit breaker	optional		optional		optional		optional		optional		optional		optional	
	Calculagraph	optional		optional		optional		optional		optional		optional		optional	
	Big Wheel	optional		optional		optional		optional		optional		optional		optional	
	Three phase voltage	optional		optional		optional		optional		optional		optional		optional	
	Current meter	optional		optional		optional		optional		optional		optional		optional	
ATS	optional		optional		optional		optional		optional		optional		optional		
Features Optional	Remote control	optional		optional		optional		optional		optional		optional		optional	
	Welding	no		no		optional		optional		optional		optional		optional	

Item		Model													
		DG2500(E)		DG3000(E)		DG4000(E)		DG5000(E)		DG6000(E)		DG7000(E)		DG8000(E)	
Generator	Frequency(Hz)	50	60	50	60	50	60	50	60	50	60	50	60	50	60
	Max.output(kW)	2	2.2	3	3.3	3.3	3.5	4.6	5	5	5.5	6.0	6.5	6.5	7.0
	Rated output(kW)	1.8	2	2.8	3	3	3.3	4.2	4.6	4.6	5	5.5	6.0	6.0	6.5
	Rated.AC voltsge(V)	120,220,230,120/240,220/380													
	Power factor(COSΦ)	COSΦ=1													
	DC outpput(V)	12V/8.3A													
	Phase	Single phase or Three phase													
	Alterator type	self-excited,2-pole,single phase or three phase alternator													
	Starting system	Recoil or Electric													
	Operating noise level(at 7m)	80-85													
	Fuel tank capacity(L)	12.5													
	Continues work(hr)	17.6	15	10.7	10	10	8.5	8.5	7.7	7.7	7.1	6.5	5.9	5.9	5.5
Engine	Model	HR170F		HR178F		HR178FA		HR186F		HR186FA		HR188FA		HR192FB	
	Engine type	Single-cylinder,vertical,4-stroke air-cooled diesel engine													
	Bore × stroke(mm)	70 × 55		78 × 62		78 × 64		86 × 70		86 × 72		88 × 75		92 × 75	
	Fule	0# or - 10# light diesel oil													
	Lubrication oil volume(L)	0.75		1.1				1.65							
	Combustion system	Direct injection													
Standard features	Voltmeter	yes	yes	yes	yes	yes	yes	yes	yes	yes	yes	yes	yes	yes	yes
	AC Output Socket	2	2	2	2	2	2	2	2	2	2	2	2	2	2
	AC circuit breaker	yes	yes	yes	yes	yes	yes	yes	yes	yes	yes	yes	yes	yes	yes
	Oil warning light	yes	yes	yes	yes	yes	yes	yes	yes	yes	yes	yes	yes	yes	yes
	Oil alert	yes	yes	yes	yes	yes	yes	yes	yes	yes	yes	yes	yes	yes	yes
	DC circuit breaker	optional	optional	optional	optional	optional	optional	optional	optional	optional	optional	optional	optional	optional	optional
	Calculagraph	optional	optional	optional	optional	optional	optional	optional	optional	optional	optional	optional	optional	optional	optional
	Big Wheel	optional	optional	optional	optional	optional	optional	optional	optional	optional	optional	optional	optional	optional	optional
	Three phase voltage	optional	optional	optional	optional	optional	optional	optional	optional	optional	optional	optional	optional	optional	optional
	Current meter	optional	optional	optional	optional	optional	optional	optional	optional	optional	optional	optional	optional	optional	optional
Features/Optional	ATS	optional	optional	optional	optional	optional	optional	optional	optional	optional	optional	optional	optional	optional	optional
	Remote control	optional	optional	optional	optional	optional	optional	optional	optional	optional	optional	optional	optional	optional	optional
	Welding	no	no	no	no	no	no	optional	optional	optional	optional	optional	optional	optional	optional

## 1-2 Basic parameters

1-2.1 Under the given conditions, the generator will output the specified power in the table listed below.

**Table 1. The generator should output its rated power under these conditions**

Height above sea level(in)	Ambient temperature(°F)	Relative humidity(%)
0	+60(+20°C)	60%

**Table 2. The generator should output reliable work and its stipulated power**

Altitude height (in)	Ambient temperature(°F)	Relative humidity(%)
(39370.08 (1000m)	41-104(5-40°C)	90%

## 1-3 General dimensions and overview of the generators

1-3.1 General dimensions of the of the CXE/LE and LN series generators

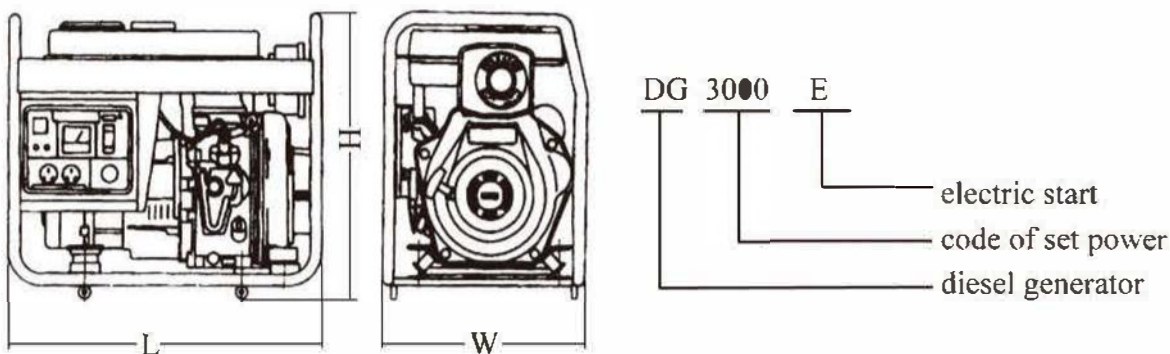

MODEL	L	W	H
DG2500(E)	610	420	520
DG3000(E)	680	475	550
DG4000(E)	680	475	550
DG5000(E)	720	485	580
DG6000(E)	720	485	580
DG7000(E)	750	485	620
DG3500SE	920	535	700
DG4500SE	952	535	700
DG5500SE	960	535	710
DG6500SE	960	535	710
DG7500SE	960	535	710

## **CHAPTER 2 OPERATING THE DIESEL GENERATOR**

### **2-1 General main points of safety during operation of the generator set.**

In order to operate the generator set safely, please follow all the instructions provided in this manual carefully. Doing so otherwise may lead to accidents and or equipment damage.

#### **2-1.1 Fire prevention**

The proper fuel for the diesel generator set is light diesel fuel. Do not use gasoline, kerosene and or other fuels other than light diesel fuel. Keep all flammable fuels away from the generators as the generator may spark and ignite these gases. In order to prevent fires from occurring and to provide enough ventilation for people and the machine, keep the diesel generator at least 1.5 meters away from buildings and or other equipment. Always operate your diesel generator on a level site. If the generator is operated on an incline, the lubricating system within the engine will not perform well and may lead to failure of the engine.

#### **2-1.2 Prevention from inhaling exhaust gases**

Never inhale exhaust gases emitted by the engine. The exhaust gases contain toxic carbon monoxide. Never operate your generator in places with poor ventilation. In order to operate this machinery indoors, a suitable ventilation system for the building is required to draw the poisonous exhaust gases out.

#### **2-1.3 Prevention from accidental burns**

Never touch the muffler and its cover when the diesel engine is running. Never touch the muffler and cover after the diesel engine has been used, as the muffler remains hot for a good period of time.

#### **2-1.4 Electric shock and short circuits**

Never touch the generator if the generator is wet. Also never touch the generator if your hand is wet. Never operate your generator if the weather conditions call for any type of precipitation such as rain, snow or fog. To prevent electrical shocks, the generator should be grounded. Use a lead to connect the grounding end of the generator to the grounding surface of choice. Please refer to Fig. 2-1 and Fig. 2-2 before beginning to use the electric generator.



Fig. 2-1



Fig. 2-2

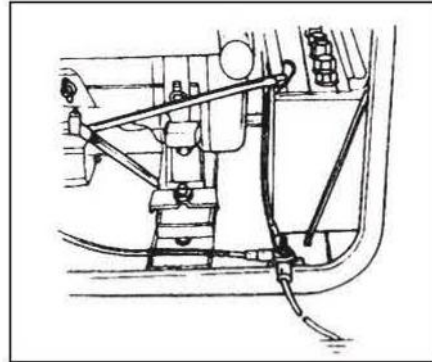

Note: When connecting devices to the generator, make sure all other devices are rated lower than the generator's output. Any generator socket should not be overloaded over its regulated limit.

### 2-1.5 Other safety points

Before operating this generator, all operators should have a good knowledge of how to break the circuit if any accidents occur. Also, all operators should be familiar with all the switches and functions of the generator before using this machine. While operating the generator, wear safe shoes and suitable clothes during operating. Always keep children and animals away from the generator.

### 2-1.6 Battery

The electrolytic liquid of the battery, also known as battery acid, contains sulfuric acid. In order to protect your eyes, skin, and clothing, wear protective gear when working with the battery. If you come in contact with the electrolytic liquid, wash it immediately with clean water. Also, if the electrolytic liquid comes in contact with your eyes, see a doctor immediately.

## 2-2 Preparation before operation

### 2-2.1 Fuel choices and fuel treatment

#### Fuel tank

Use only light diesel fuel. The fuel should be filtered clean. Never let dust and water mix with fuel in the fuel tank. Otherwise it will clog the fuel lines and oil nozzles. It may also damage your pressure pump.

Note: It is dangerous to overfill the fuel tank. Never exceed the red piston in the filter.

Type	3500 Series	5500 Series	6500 Series
The effective volume of fuel tank: (L), England gallon	5.5 (1.21)	11.3 (2.49)	14.6 (3.21)

#### Air filter element

Do not wash the air filter. The element is made of dry material, which does not permit washing. When the output of the diesel engine is bad or the color of the exhaust gas is abnormal, replace the air filter element. Never start the diesel engine without the air filter.

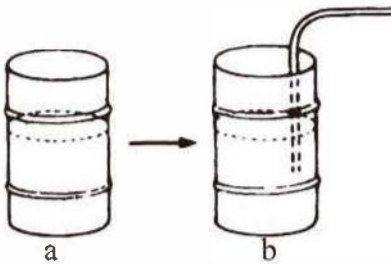

- After purchasing fuel, put it into a drum and let it sit for 3-4 days.
- 3-4 days later, insert half of the fuel sucker into the drum (water and impurities stay in the lower portion of the drum)

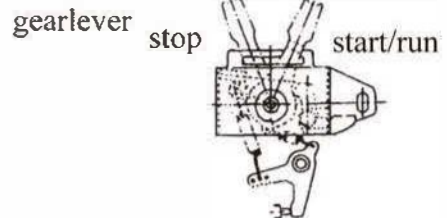

#### Note:

Never smoke near the opening of the fuel tank. Do not let sparks get near the fuel tank and do not overfill tank. After filling, tighten the fuel cap.

## 2-2.2 Filling engine oil

### Pouring inlet of lubricating oil

Put the generator set at level state, Fill the lubricating oil to it till the inlet. At the same time. Check the oil level with dipstick. It is necessary only to insert the dipstick lightly. Caution: don't rotate the dipstick.

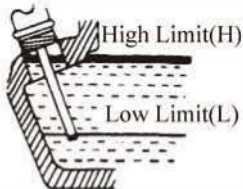

Type	3500series	5500series	6500series
Volume (L)	0.75	1.1	1.65
England gallon	(0.16)	(0.24)	(0.36)

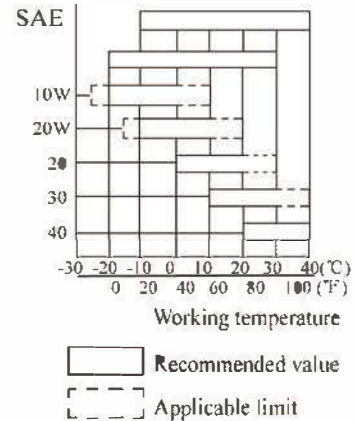

### A.P.I

Classification of maintenance for diesel engine  
The lubrication oil should be CC or CD grade.

Engine oil is the most important factor in determining the life of your generator engine. If you use poor engine oil or if you don't change the oil regularly, the piston and cylinder will wear easily or seize up. Also, the life of the other parts in your engine such as bearings, and other rotating parts will shorten considerably.

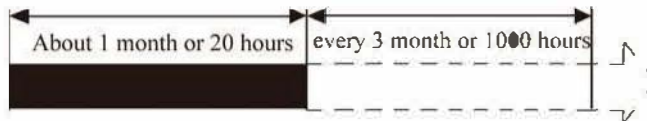

### Time to change engine oil

Although there is an alarm system to check for low oil pressure, it is always a good idea to check the amount of oil inside the engine. If the oil level is low, fill it before starting the engine. A good time to drain the oil from the engine is when the diesel engine is still hot. If the engine is fully cooled, it is more difficult to drain all the oil out or some impurities will remain in the engine.

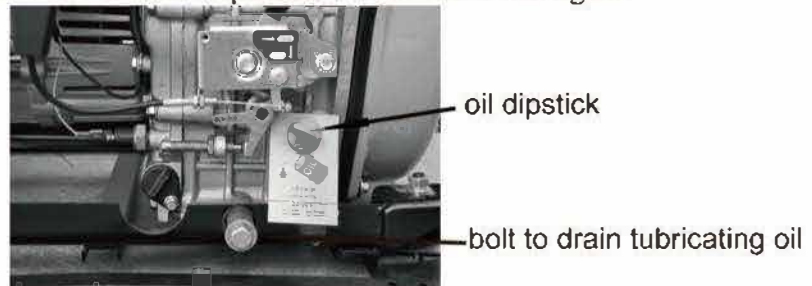

**Warning: Don't fill engine oil when diesel is operating.**

### 2-2.3 Check the air filter

(1) Loosen the butterfly nut, take the cover of the air filter off and take the air filter element out.



Do not use detergent to wash the air filter element. When the performance of the engine decreases or when the color of the exhaust gases is bad, exchange the filter element. Never start the engine without the air filter as foreign objects may enter the intake and damage the engine.



(2) After replacing the air filter element, replace the cover and tighten the butterfly nut firmly.

### 2-2.4 Checking the generator



*(Note: Only certain welder generator sets have an electric fan incorporated on them.)*

Before starting the generator, make sure the air switch is in the "off" position. Starting the generator with the switch in the "on" position is very dangerous.

The generator should be grounded in order to prevent electric shock.

Use dry compressed air (with pressure about  $1.96 \times 10^5 \text{Pa}$ ) to blow the dust out in the electric control cabinet and at the surface of the generator. Check to see how clean the surface of the sliding ring is. Check the pressure of the carbon brush. Also, check whether the position of the carbon brush at the sliding ring is correct and the fixture is reliable with a good contact.

According to the electric wiring diagram, check to see whether the connecting wire is correct and the connected place is firm.

Use a  $500\text{M}\Omega$  meter to measure the insulation resistance of the electrical part. The resistance should be no less than  $5\text{M}\Omega$ . When measuring devices, make sure the capacitor is turned off. Otherwise, it will burn the capacitor. (For the low noise set, the inspection may not be performed).

2-2.5 The fuel and oil in a new engine is drained before sold. Before you start the engine, please fill the fuel tank and engine oil first. Then, check to see if there are air bubbles in the engine. If there are, follow these procedures. Loosen the connecting nut between the oil injection pump and oil pipe. Bleed the air from the system until there are no more bubbles. Then replace the connecting nut and tighten it.

### 2-3 Checking the operation of the diesel engine

#### 2-3.1 Low-pressure alarm system.

Diesel engines have a low-pressure sensor system where if the oil pressure drops to low, the sensor will shut the engine off. The purpose of having this system is to ensure that the engine does not seize up. If there is not enough oil in the engine, the temperature of the oil will be raised too high. On the contrary, if there is too much oil in the engine, the engine oil can slow the engine down considerably.

#### 2-3.2 Engine break in

When you purchase a brand new engine, the engine must be properly broken in. The break in period is about 20 hours.

- (1) Avoid overloading the engine when brand new.
- (2) Change the engine oil according to specifications. An oil change for a brand new engine is about 20 hours or every month, an older engine, the oil change is about 100 hours or three months.

### 2-4 Starting the generator set

#### 2-4.1 Manual starting.

Start the engine in accordance with procedures below:

- (1) Take the oil pipe away from the fuel pump, discharge the air inside.
- (2) Then reconnecting the oil pipe.



speed handle

(3) Pull the recoil starter handle out until you feel resistance. It will reset to its original position automatically. The handle should be reset into its recoil device slowly to prolong the life of the life of the engine starter.

(4) In cold climate, it is difficult to start the engine. To remedy this, pull the rubber plug out from the rocker of the diesel engine and fill 2 ml of engine oil. Before starting, put the rubber plug back in place. If you don't put the rubber plug back in place, rain, dust and other dirt can enter into the diesel engine. It will cause the parts inside the diesel engine to wear quickly and lead to engine failure.

#### 2-4.2 Electric starting

The procedures for preparing to start the engine are the same as the manual starting engine.

1. Insert key into ignition and put it in the "off" position.
2. Put the speed handle in the "Run" position.

3. Turn the start switch clockwise to the “START” position. To set the silent type, first turn it clockwise to the “RUN”(ON) position for 1-2 seconds. The electromagnetic iron will be triggered, now turn it clockwise to the “START” position.
4. After the diesel engine is started, remove your hand from the switch handle; the switch will automatically reset itself to the “●N” position.
5. If the engine is not starting after 10 seconds of cranking, wait about 15 seconds before trying it again. If you crank too long, the voltage of the battery will drop. This can lead to improper ignition. When the diesel engine is operating, let the ignition retain on the “ON” position.

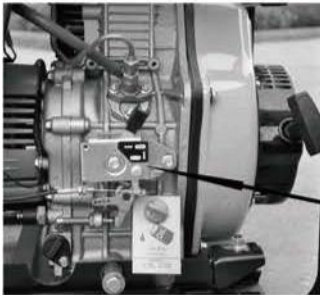

speed handle

**Note:**

If you crank the starter too long, the battery may be drained too much to provide enough energy for proper engine ignition. Also, when the diesel engine is operating, let the key remain in the “ON” position.

## 2-5 Procedures for starting the generator set

This procedure applies to the L series recoil starting style models.

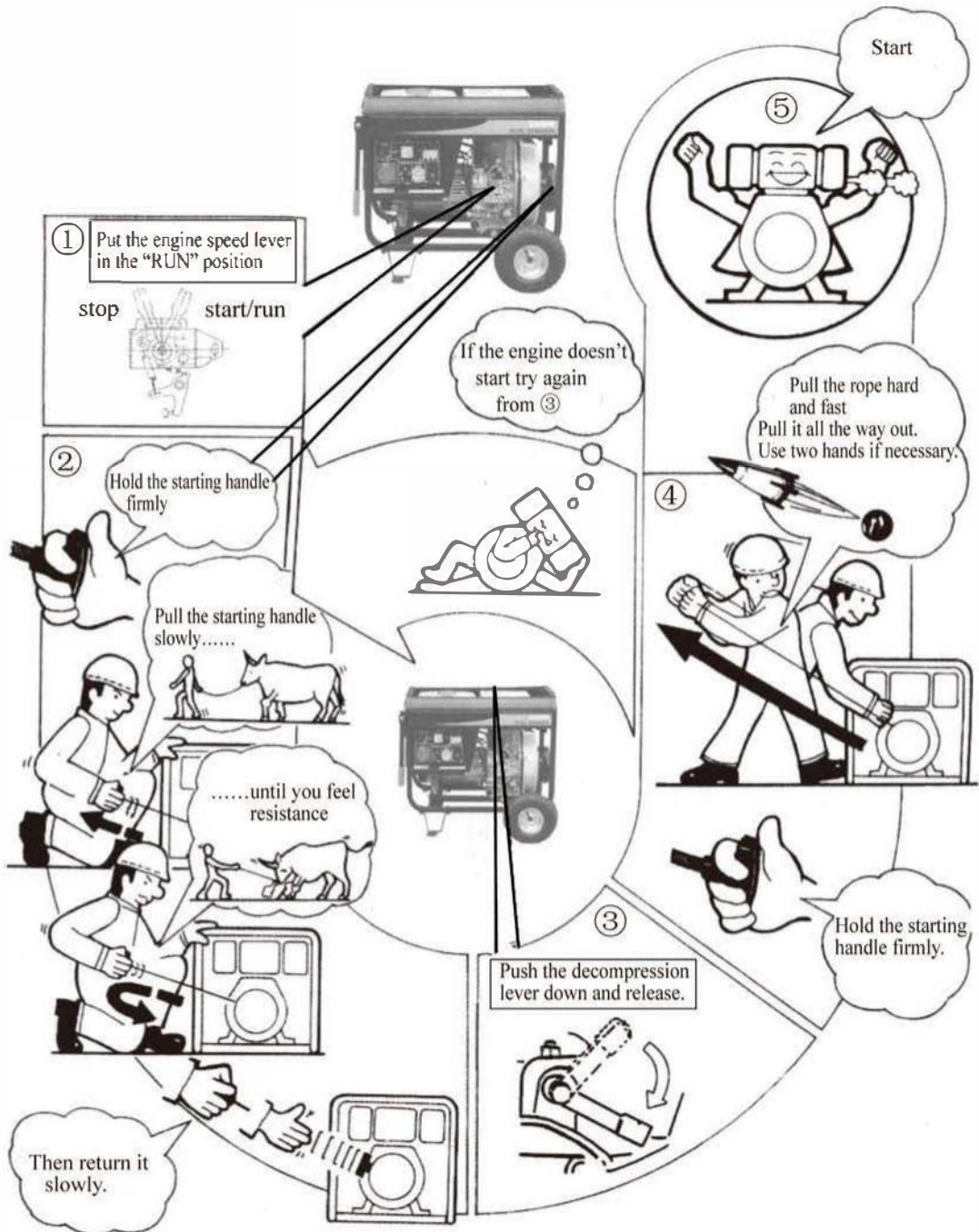

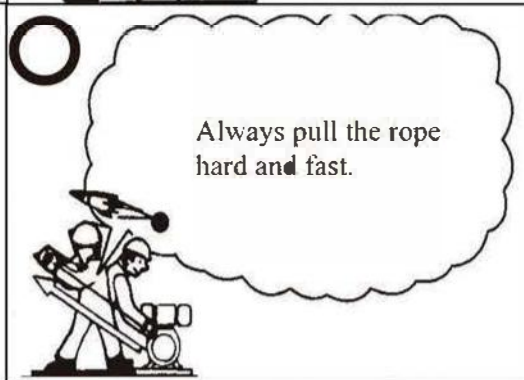
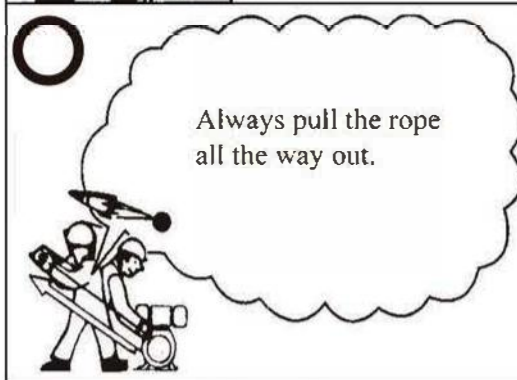
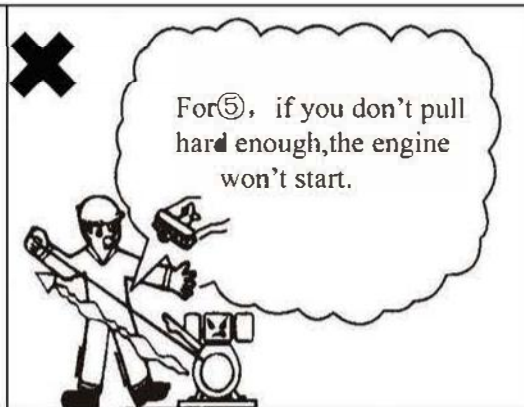
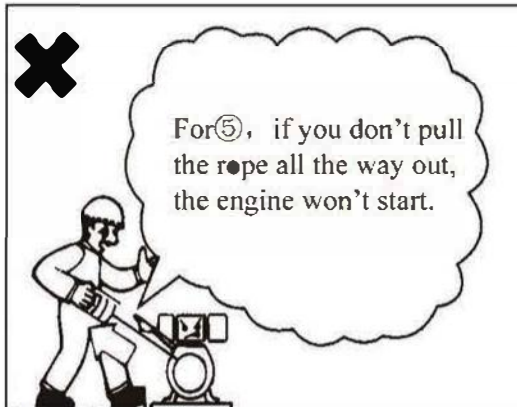
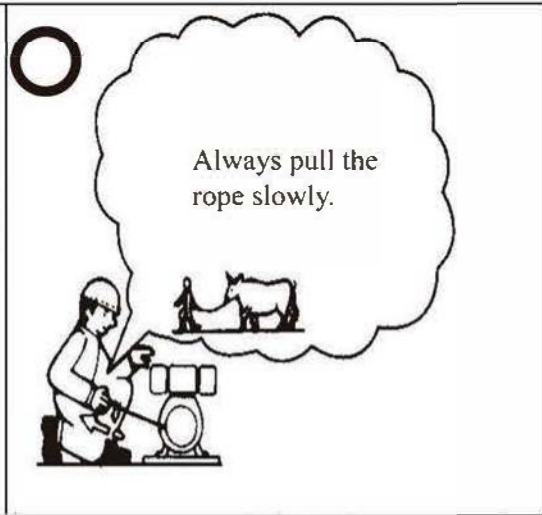
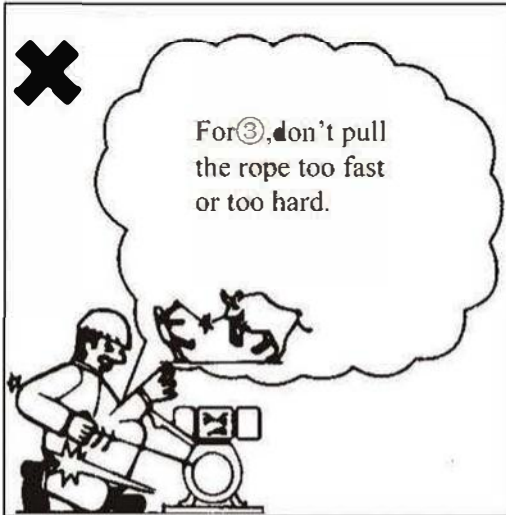



## 2-6 Proper operation of the generator set

### 2-6.1 Operating the diesel engine

1. Pre-heat the diesel engine for 3 minutes under no load conditions.
2. First check the height of the lubricating oil level, if it is low, refill it. Our diesel engines are equipped with an alarm system that will notify you if the oil pressure is too low. The alarm system will shut down the engine if the oil pressure is too low.
3. Do not adjust the speed limit regulation bolt or the fuel adjustment bolt. These bolts have been set by the factory already, changing them will affect the properties of the engine performance.

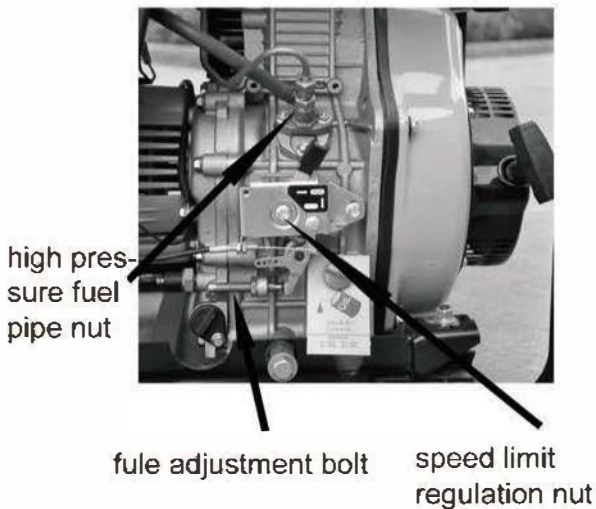

### 2-6.2 Checks during engine operation

1. Check to see if there are abnormal noises.
2. Check to see if the performance is good or bad.
3. Check the color of the exhaust gases (whether it is too black or too white). If any of these conditions exist. Stop the engine and find the cause of the problem. If no problems are found, please contact your local dealer or our nearest company branch.

## 2-7 Loading

### 2-7.1 Load conditions

Exert loads in accordance with the specified parameters.

### 2-7.2 Output of electricity

1. Raise the revolutions per minute (turn the speed handle to the max setting) of the generator to get the maximum power out of the generator. If not, the automatic voltage regulator device will excite and doing this for long periods of time will cause the capacitor to burn. For the rated speed of the generator, please refer to Chapter 1, item 1-1 technical specification and data.
2. Observe the pointer of the voltmeter, it should point to  $230V \pm 5\%$  (50Hz). (For 60Hz set, it will be  $240V \pm 5\%$ ). Meanwhile put the switch in the GEN (generator) position. The AC voltage

from the socket of the power supply can be output.

3. When connecting devices to the generator, make sure to connect these devices in order. Connect the large loads onto the generator first. If everything is functional, smaller loads can then be added. If the generator shuts off, it may be because the load being drawn by all the various devices are too high. In this event, decrease the number of small devices until everything is functional. The total drawn power should not exceed the maximum output power of the generator. Please see Table 1-1 for technical specifications of what the generator can output. In order to reset the generator after overdrawn power, let it sit for several minutes. If the indication of the voltmeter is too high or too low, adjust the speed accordingly. If there are problems, stop the generator immediately and fix the issue.
4. During operation, the generator should be in a place that has very good ventilation. Never cover the engine to solve a ventilation problem, as this will damage your equipment.

**Table 2-1**

Note: Do not start more than two devices simultaneously. Each device should be started one by one to prevent overloading the generator.

The generator should be running at 3600 revolutions per minute in order to achieve the (60Hz) frequency. The speed of the engine can be adjusted from the speed governor.

### 2-7.3 Charging the battery

1. For the electric starter on the generator, the 12V battery is automatically charged through the regulator on the side of the engine when it is running.
2. If the generator is not used for long periods of time, the battery should be disconnected to avoid energy loss from the battery.
3. Do not connect the negative and positive terminals of the battery together at any time. Doing so will damage the battery.
4. Do not reverse the polarities when attaching the battery cables to the battery. Doing so will damage both the battery and the electric starter.
5. When charging the battery, the battery produces flammable gases. Do not smoke, let flames, and sparks get near the battery while it is charging as this may cause a fire. To avoid sparking

while connecting the cables to the battery, first, connect the cables to the battery then to the motor, To disconnect battery cables, first disconnect the motor end of the cable.

## 2-8 Stopping the generator

1. Take the electrical load off the generator.
2. Put the speed handle in the "RUN" position and let the engine run for 3 minutes after unloading. Do not stop the diesel engine immediately let it warm down. Stopping the diesel engine suddenly may raise the temperature of the engine abnormally and lock the nozzle and damage the diesel engine.
3. Press down on the brake handle.
4. If equipped with an electric starter, turn the key to the "Off" position.
5. Put the fuel handle to the "S" position.
6. Finally, pull slowly on the recoil handle until you feel resistance (this is when the piston is on the compression stroke, where the intake and exhaust valves are closed). What this does is prevent the engine from rusting when not in use.

**Note:**

1. If the speed handle is in the "Stop" position and the engine is still running, loosen the high pressure oil pipe nut. The engine could be stopped more than one-way other than the speed handle way.
2. If you cannot stop the engine with a load on it, then remove the load first then stop the engine.

## CHAPTER 3 MAINTENANCE

Keeping your generator well maintained will prolong the life of your generator, Everything needs to be checked including the diesel engine, welder, generator, control cabinet, and frame. For overhauling procedures, please refer to the instruction manual of the relative subassembly. If you need these manuals, please call our company and we will send you one.

Before starting the maintenance, make sure the diesel engine is off.

Please refer to the Table 3-1 for the proper maintenance schedule.

**Table 3-1. Maintenance schedule for diesel generator set**

Interval of maintenanc Item	Everyday	1st month or after 20 hours	3rd month or 100 hours	6th month or 500 hours	Every year or 1000 hours
Check and fill enough fuel	○				
Discharge fuel		○			
Check and fill enough engine oil	○				
Check whether it leaks oil	○				
Check and screw each fastened part	○			● Screw the bolt of cylinder head firmly	
Exchange engine oil		○ (1st time)	○ (2nd timr late)		
Clean filter of engine oil				○ (Exc hange)	
Exchange air filter element	If operated at dusty region, the period of maintenance should be shorten			○ (Exchange)	
Clean filter of fuel				○	● (Exchange)
Check high pressure oil pump				●	
Check nozzle				●	
Check fuel pipe				● (If necessary, exchange it)	
Adjust the gaps of air intake and air exhausted gate		● (1st time)		●	
Grind air intake and air exhausted gate					●
Exchange piston ring					●
Check electrolytic solution of accumulator	(each month)				
Check electric brush and slide ring				●	
Check insulation resistance	The time of stop is over 10 days.				○

Note: "●" mark indicates that it needs spacial wrench, please contact with dealer.

### 3-1.1 Changing the engine oil(every 100 hours)

Take the oil cover out. Remove the oil drain plug when the diesel engine is still hot. Be careful of hot oil and hot engine as you may get burned. The bolt is located at the bottom of the cylinder. After draining the oil, put the bolt back and tighten it. Then fill with the proper engine oil to the proper level.

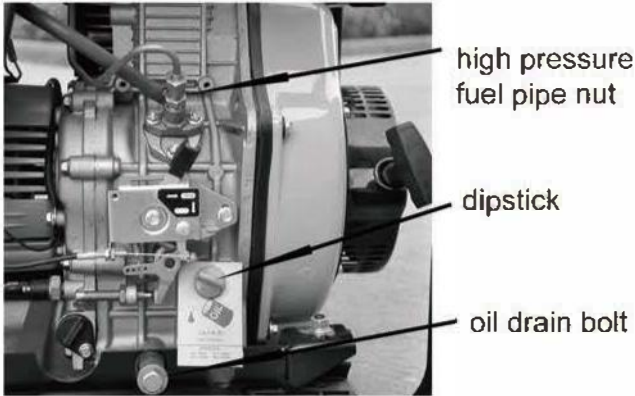

### 3-1.2 Air filter maintenance schedule

1. Clean air-filter every 6 months or 500 hours of operation.
2. If necessary, exchange it.
3. Do not use detergent to clean air filter element.

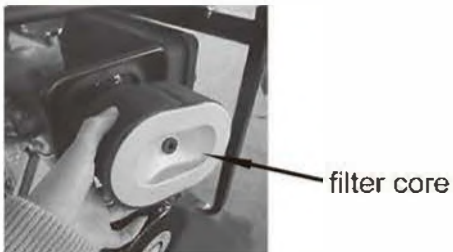

**Note:**

Never start the engine without the air filter. This can cause serious damage to the engine if foreign objects enter the intake system. Always change the air filter on time.

### 3-1.3 Fuel filter maintenance

1. The fuel filter should be cleaned often to keep the engine running at maximum performance.
2. The recommended time period for cleaning the fuel filter is 6 months or 500 hours of operation.
  - a. To do this, first drain the fuel from the fuel tank.
  - b. Loosen the small screws on the fuel switch and remove the fuel filter from the port. Use diesel fuel to clean the fuel filter. Also, remove the fuel injector and clean the carbon deposit around it. The recommended time period for this is 3 months or 100 hours.

### 3-1.4 Cylinder head bolt tensions

The cylinder head bolts should be tightened to specifications please refer to the diesel engine manual for specifications and the special tools required to do this.

### 3-2 Storing for long periods of time

If your generator needs to be stored for long periods of time, the following preparations should be made.

1. Start the diesel engine for 3 minutes then stop it.
2. When the engine is still hot, change the engine oil with new engine oil of the proper grade.
3. Pull the rubber plug out of the cylinder head cover and put 2CC of lubricating oil in it, then cover the plughole up again.
4. For manual starting generator welders, press the decompression handle down and pull the recoil handle 2 or 3 times. This pushes the intake out. (Do not start the engine)
5. For electric started generator, press the decompression handle down and crank the engine for 2-3 seconds. To do this, put the starter switch in the "Start" position. (Do not start the diesel engine)
6. Finally, pull the recoil starter until you feel resistance; this is when the piston is on the compression stroke where the intake and exhaust valves are closed. Having the intake and exhaust valves closed will prevent rust, as moisture cannot get inside the combustion chamber
7. Clean the engine and store it in a dry place.

## CHAPTER 4 TROUBLESHOOTING

### 4-1 Troubleshooting procedures

Causes of malfunction		Remedy
Diesel cannot be started.	Not enough fuel	Add enough fuel
	The switch of fuel is not at "OPEN" position	Turn the switch of fuel to "OPEN" position
	High-pressure pump and nozzle do not inject fuel or the injected amount is less.	Disassemble the nozzle and adjust it at test table.
	Speed control lever is not at "RUN" position.	Turn speed control lever to "RUN" position.
	Check level of lubrication oil.	The standard oil amount of lubricating oil should be between high graduation "H" and low graduation "L"
	It is not quick and powerful to pull reactive atarter.	Start diesel engine in accordance with the requirements of "start operation procedures"
	Nozzle exists dirt.	Clean the nozzle.
	Accumulator has not electricity.	Charge the accumulator or exchange it.
Generator cannot generate electricity and has no welding voltage.	Master switch(NFB)is not be switched on	Turn master switch handle to "ON" position.
	Carbon brush of generator was worn.The contact is bad.	Exchange the carbon brush.
	The contact of socket is bad.	Adjust the contact feet of socket.
	The rated revolution of engine cannot be reached.	Make it reach to the rated revolution in accordance with the requirements.
	AVR automatic governor is damaged.	Exchange it.
	The potentiometer of current regulation for electric welding is damaged.	Exchange it.

If you are still having trouble, please contact with your nearest dealer or with our company directly if necessary.

### 4-2 Questions and doubts

If you do not understand anything or have any questions, please feel free to contact your local dealer or with our company directly. Below is a list of some information you should have ready before contacting your local dealer or us.

1. Model of diesel engine generator and engine model number.
2. State of residency.
3. Number of hours of operating equipment along with the problem that occurred.
4. A detailed condition and time when the problem occurred, in other words, climate and atmosphere.

## Chapter 5 PART LISTINGS

### Overall view of engine generator assembly

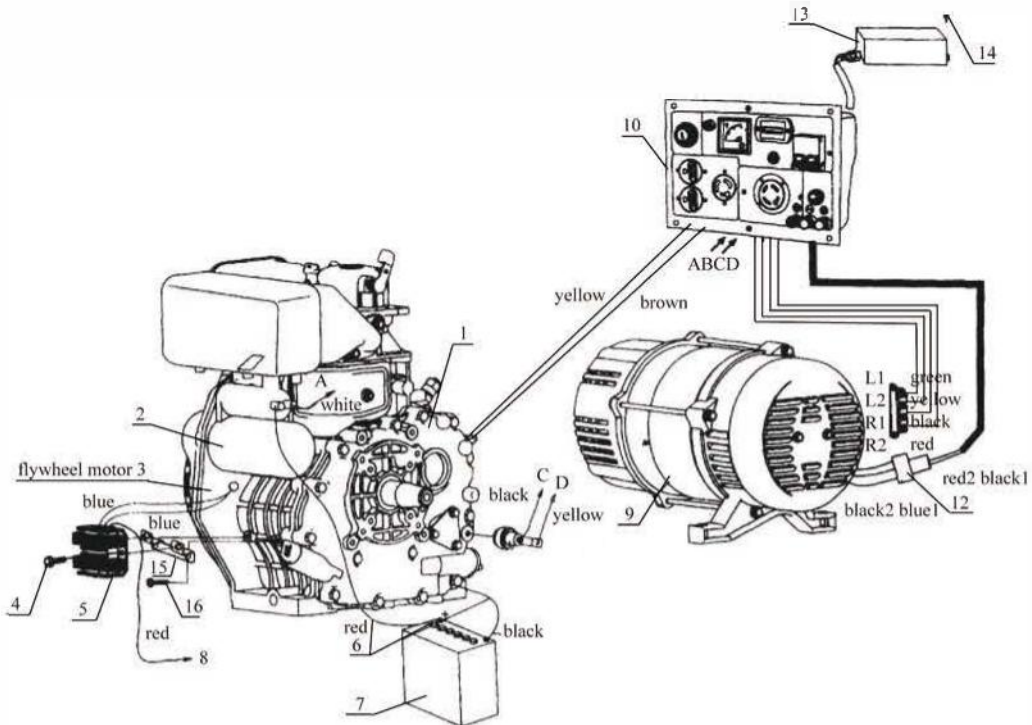

1	Series diesel engine	1
2	Starter Motot	1
3	Flywheel generator	1
4	Bolt	2
5	Voltage Regulator	1
6	Battery Cable(red,black)	2
7	Battery	1
8	Oil level sensor	1
9	Generator	1
10	Output panel assembly	1
11	Throttle cable	2
12	Connector assembly	1
13	Capacitor	1
14	Bolt	2
15	Voltage Regulator Bracket	1
16	Bolt	2



## Exploded view of frame assembly

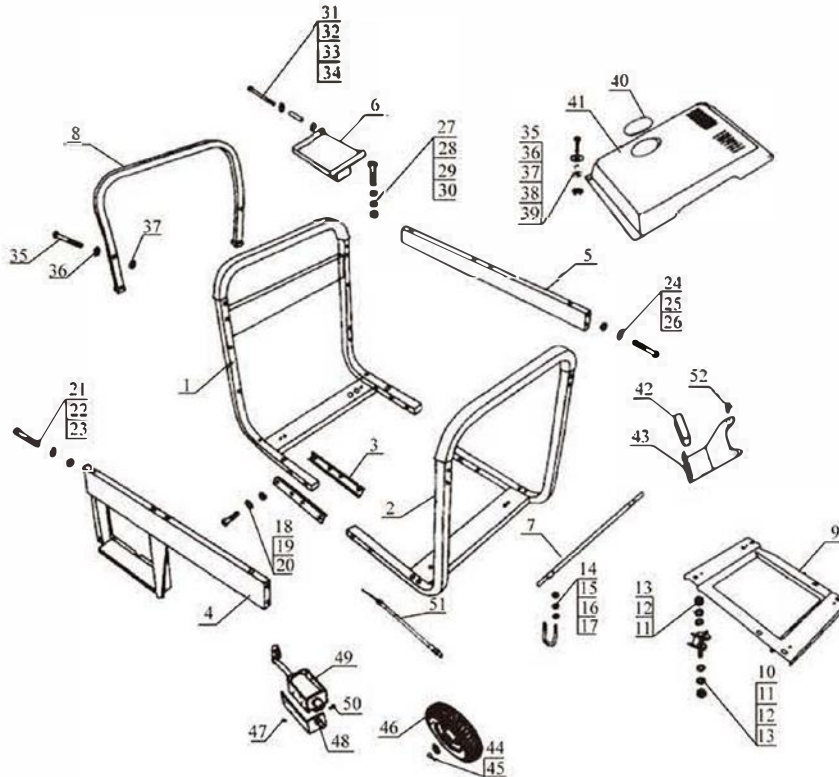

Number	Part Description	Quantity
1	Left frame	1
2	Right frame	1
3	Board connected	4
4	Output panel bracket	1
5	Back board	1
6	Battery tray	1
7	Axle	2
8	Handrail	1
9	Carrier frame	1
10	Rubber mount	4
11	Washer 10	8
12	Spring washer 10	8
13	Nut M10	8
14	Nut M6	8
15	Spring washer 6	8

<b>Number</b>	<b>Part Description</b>	<b>Quantity</b>
16	Washer 6	8
17	U bolt	4
18	Nylon nut M8	8
19	Nylon washer 8	9
20	Hexagon socket head cap screw	8
21	Hexagon socket head cap screw	1
22	Nylon washer 6	1
23	Nylon nut M6	1
24	Nylon nut M6	1
25	Nylon washer 6	1
26	Hexagon socket head cap screw	1
27	Bolt	1
28	Washer 10	1
29	Spring washer 10	1
30	Nut M10	1
31	Hexagon socket head cap screw	1
32	Spring washer 6	1
33	Steel tube	1
34	Nylon nut 6	1
35	Bolt	4
36	Flat washer M6	4
37	Shock absorber	4
38	Washer 6	4
39	Nut M6	4
40	Rubber cover	1
41	Decorative cover	1
42	Rubber absorber	1
43	Plate connecting engine and frame	1
44	Flat washer	4
45	Split pin	4
46	Wheel	4
47	Bolt	1
48	Magnet bracket	1
49	Magnet	1
50	Magnet cable bolts	1
51	Throttle cable	2
52	Bolt	2

## *Electric panel parts drawing*

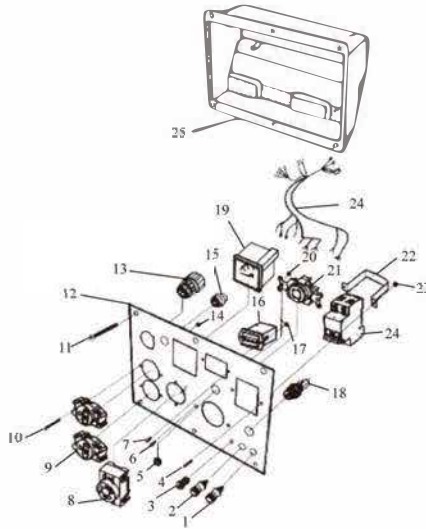

Number	Part Description	Quantity
1	Positive DC port	1
2	Negative DC port	1
3	Grounded hole	1
4	Bolt	2
5	Large Nut	1
6	Bolt	2
7	Bolt	2
8	3 Prong socket	1
9	Current Adjusting Switch	1
10	Bolt	6
11	Electric panel bolt	6
12	Electric Panel	1
13	Starter switch	1
14	Large nut	6
15	Oil alert lamp	1
16	Hour meter	1
17	Hour meter bolts	2
18	DC Fuse	1

Number	Part Description	Quantity
19	Voltmeter	1
20	Nut	2
21	4 prong socket	1
22	Breaker bracket	1
23	Nut	2
24	Breaker	1
25	Wiring harness	1
26	Electrical box	1

### *Generator head assembly*

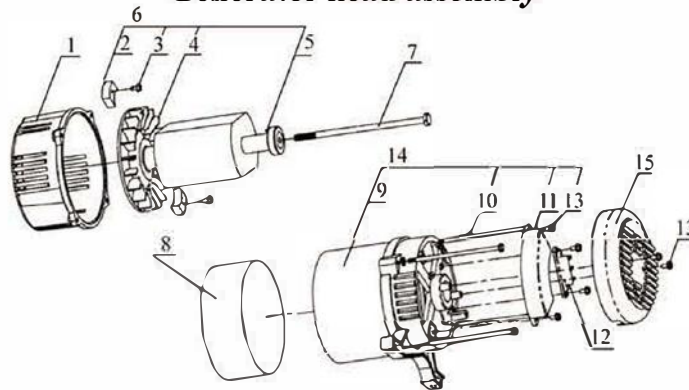

Number	Part Description	Quantity
1	Voltmeter	1
2	Nut	2
3	4 prong socket	2
4	Breaker bracket	1
5	Nut	1
6	Breaker	1
7	Wiring harness	1
8	Electrical box	1
9	Stator	1
10	Long bolt	4
11	Capacitor	1
12	Wiring Seat	1
13	M5x15 Bolt	6
14	Stator Unit	1
15	Dust Cover	1

### **Fuel system components**

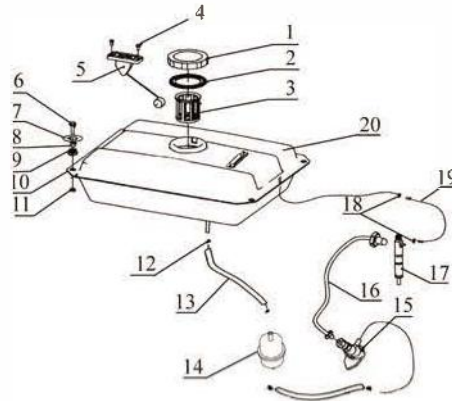

<b>Number</b>	<b>Part Description</b>	<b>Quantity</b>
1	Fuel Cap	1
2	Seal	1
3	Filtering cup	1
4	M5x10screw	2
5	Fuel lever indicator	1
6	M6x25 a Bolt	4
7	Large flat washer 6	4
8	Fuel tank lining	4
9	Shock absorbing gasket	4
10	Fuel tank	1
11	M6 Nut	4
12	Clip of fuel inlet pipe	2
13	fuel inlet pipe	1
14	Disposable fuel filter	1
15	High pressure fuel pump	1
16	Parts of high pressure fuel pipe	1
17	Fuel injector	1
18	Clip of fuel leak-off pipe	2
19	Fuel leak-off pipe	1
20	Fuel tank	1

**Fig.n muffler**

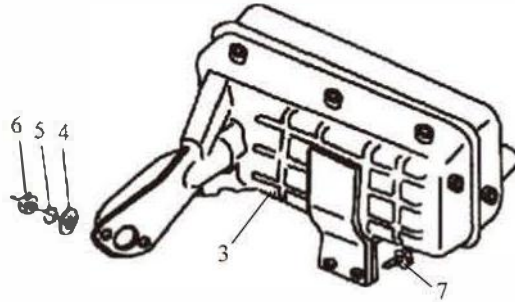

Number	Part Description	Quantity
3	Muffler	1
4	Washer 8	2
5	Washer 8	2
6	Nut M8	2
7	Bolt M8 x 12	2

**Fig.0 starting motor**

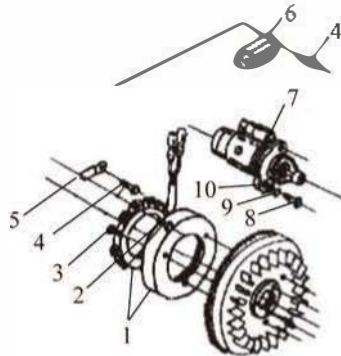

Number	Part Description	Quantity
1	Flywheel generator	1
2	Bolt M6 x 30	3
3	Screw M6 x 12	3
4	Bolt M6 x 12	3
5	Clamp	1
6	Regulator	1
7	Starting motor	1
8	Bolt M10 x 35	2
9	Washer 10	2
10	Washer 10	2

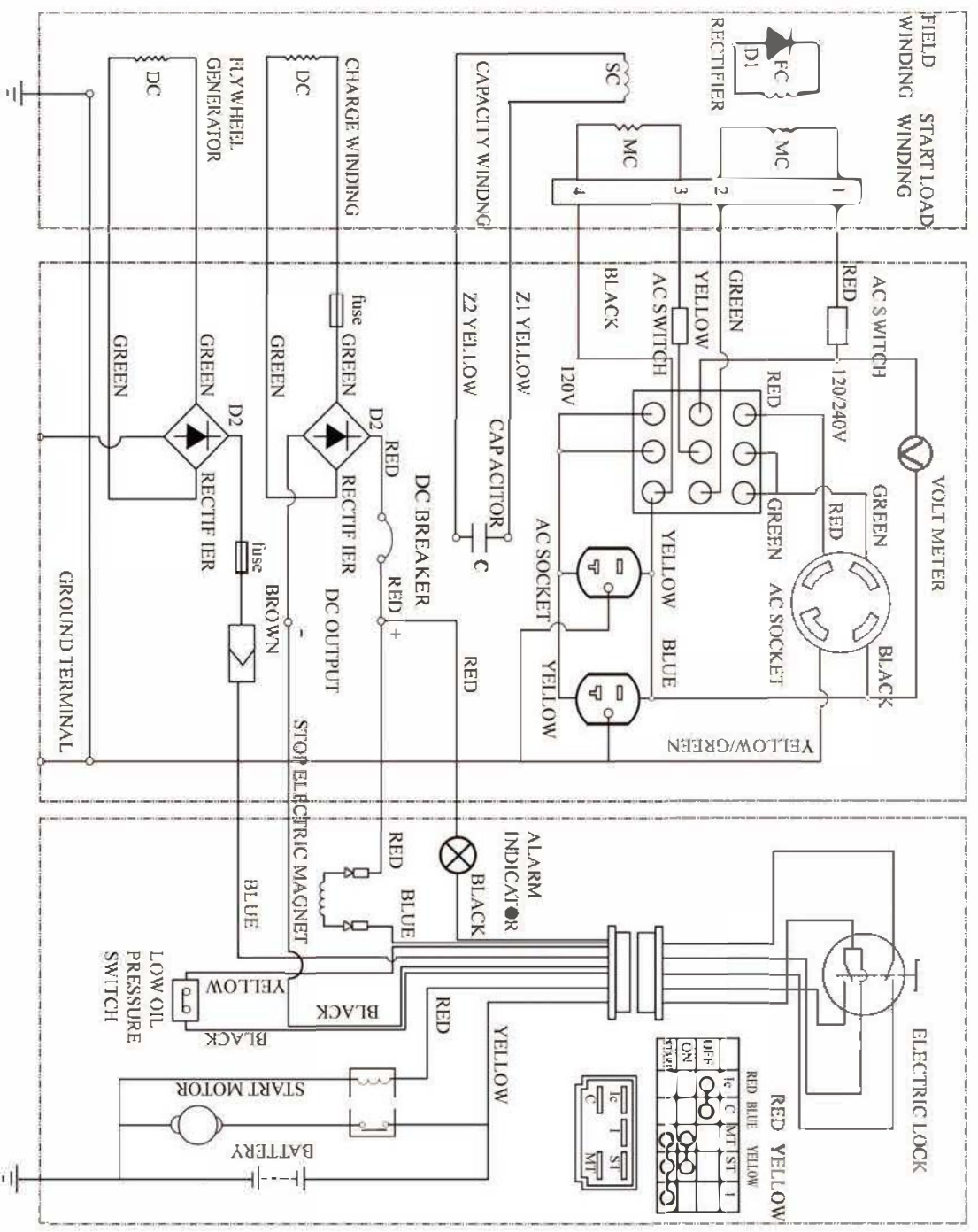

2500 5000 6000SE

